



**1269 MHz Loop Yagi Kit, Model 2445LYK
SPECIFICATIONS**

Frequency range:	1.22 to 1.285 GHz	Gain:	≅ 20 dBi
Number of elements:	45	3 dB Beamwidth	
Boom length:	144 inches	(E plane):	≅ 16°
Boom diameter:	1.0 inch	F/B ratio:	≥ 20 dB
Mast diameter:	1 1/2 in. max	Maximum Power:	550 W average
Weight:	5 pounds	Stacking distance:	24 inches vertical
Connector:	Type-N female		26 inches horizontal

PARTS LIST

<i>Quantity</i>	<i>Description</i>	<i>Quantity</i>	<i>Description</i>
2 pcs	drilled boom	1 pkg	4-40 stainless steel screws
1	reflector 1 (1/4")		nuts, lockwashers, 8-32 misc.
1	reflector 2 (3/8")		hardware
1	driven element	1	BM (boom to mast) bracket
4	directors 1-4	1	3 1/2 x 4" boom to mast plate
7	directors 5-11	1	1 1/2" U-bolt with nuts & saddle
6	dieectors 12-17	1 pkg	cable assembly with connector
6	directors 18-23		
12	directors 24-35		
7	directors 36-42		

ASSEMBLY INSTRUCTIONS

1) Put the two piece boom together. The splice is between elements D22 & D23, and is secured by the loop mounting screws. Attach loops to the boom with 4-40 x 1 1/4" screws, lock washers and nuts in proper sequence. Loops go on the side of the boom marked "TOP" or "X". When tightening the nuts on the parasitic elements, be careful not to torque them too tightly. Snug down the nuts, align the elements and use a screwdriver for the final tightening. A 1/4" nut driver is almost mandatory for this job! Attach the driven element with the 5/16-18 stainless steel nut. If only a single antenna is being built, it does not matter which way the loop is oriented. If antennas are to be stacked, see "Instructions for Stacking Loop Yagis."

2) Attach the boom-to-mast (BM) bracket and the 3 1/2 x 4" mtg plate with 8-32 hardware. The mounting center is D-20. Install U-bolt so that the mast is directly under the boom.

3) Install the connector-cable assembly through the hole in the driven element mounting bolt and and solder the coax ends to the ends of the loop. Solder the inner conductor first. Bend the connector bracket forward and secure it to the boom. (The bracket is secured by the nut for D-1) Attach the feedline and tape it to the bottom of the boom. Seal all connections with silicone RTV or equivalent.

4) The SWR should be 1.5:1 or better. Additional tweaking can be accomplished by adjusting the distance between the driven element and R1 or by adjusting the shape of the driven element.



DIRECTIVE SYSTEMS

177 DIXON RD.
LEBANON, ME. 04027
TEL: 207-658-7758 FAX: 207-658-4337
www.directivesystems.com

DIMENSIONS OF 1269 MHz LOOP YAGI, MODEL 2445LY(K)

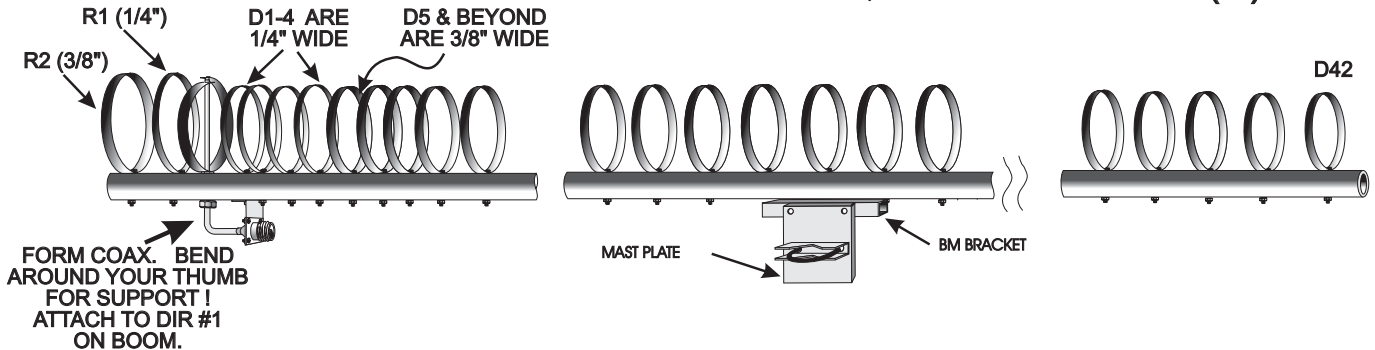

Element	Spacing From end of boom	Circumference	Element	Spacing from end of boom	Circumference	Element	Spacing from end of boom	Circumference
R2	0.000	10.000	D13	38.040	8.274	D28	91.440	7.905
R1	3.100	10.060	D14	41.600	8.274	D29	95.000	7.905
DE	4.050	9.586	D15	45.160	8.274	D30	98.560	7.905
D1	5.170	8.584	D16	48.720	8.274	D31	102.120	7.905
D2	6.000	8.584	D17	52.280	8.274	D32	105.680	7.905
D3	7.780	8.584	D18	55.840	8.008	D33	109.240	7.905
D4	9.560	8.584	D19	59.400	8.008	D34	112.800	7.905
D5	10.810	8.534	D20	62.960	8.008	D35	116.360	7.905
D6	13.120	8.534	D21	66.520	8.008	D36	119.920	7.805
D7	16.680	8.534	D22	70.080	8.008	D37	123.480	7.805
D8	20.240	8.534	D23	73.640	8.008	D38	127.040	7.805
D9	23.800	8.534	D24	77.200	7.905	D39	130.600	7.805
D10	27.360	8.534	D25	80.760	7.905	D40	134.160	7.805
D11	30.920	8.534	D26	84.320	7.905	D41	137.720	7.805
D12	34.480	8.274	D27	87.880	7.905	D42	141.280	7.805

Note: All dimensions are in inches

The boom diameter is 1.0 inch, and the loop mounting holes are drilled for 4-40 hardware (no. 33 drill bit). The driven element hole is enlarged to 5/16 inch. All elements are 0.032 inch thick and 0.375 inch wide except R1 & D1 thru D4 which are 0.250" wide.. Note that the element spacing from D7 on is 3.560 inches. The brass driven element is installed in the 5/16" hole in the boom. The feed coaxial cable (0.141 inch semi rigid) goes through the mounting bolt of the driven element, and is soldered to the open ends of the element. Form the coax around your thumb, and attach to the boom using Dir#1 hardware. For best match, the driven element should be approximately 2.75 inches high; this makes it wider than it is tall. This shape can be adjusted for best match. This antenna is based on work done by G3JVL.

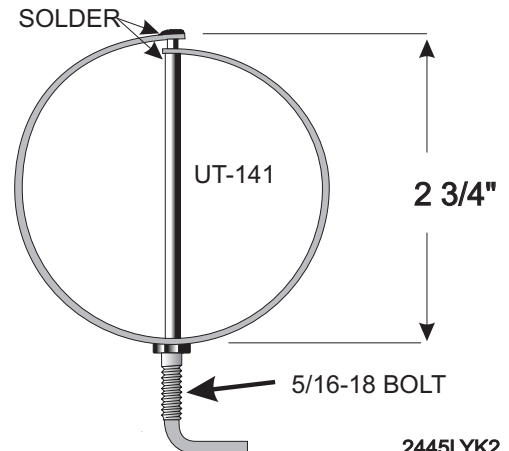

2445LYK2
05/02