



DIRECTIVE SYSTEMS

177 DIXON RD.
LEBANON, ME. 04027
TEL: 207-658-7758 FAX: 207-658-4337
www.directivesystems.com

903 MHz Loop Yagi Kit, Model 3347LYK

SPECIFICATIONS

Frequency Range:	880-920 MHz	Gain:	20.5 dBi
Number of elements:	47	3 dB Beamwidth: (E Plane:)	14.4°
Boom Length:	216 inches	F/B ratio:	>20 dB
Boom diameter:	1 inch	Maximum Power:	550 W. average
Mast diameter:	2 inch max.	Stacking distance:	38 inches vertical 41 inches horizontal
Weight:	8 pounds		
Connector:	Type N female		

PARTS LIST

Quantity	Description	Quantity	Description
3 pcs.	drilled boom	1 pkg	Hardware bag (listed on last page)
2	reflector 1,2	2	Sub boom splice shells 6 3/4 X 1"
1	driven element	3	boom to mast bracket (BM bracket)
1	directors 1-11	2	sub boom sections 1" X 53"
11	directors 12-18	1	boom to mast plate for 2" U-bolts
7	directors 19-24	2	Sub boom plates 3.5 x 4"
12	directors 25-36	2	2" U-bolts with hardware & saddles
8	directors 37-44	1	cable assembly with connector & bracket

ASSEMBLY INSTRUCTIONS

- 1) Attach loops to the boom with 1 1/4" x 4-40 screws, nuts and lockwashers in proper sequence. Loops go on the side of the boom marked with an "x" or "top". Open only one bag of loops at a time, to avoid mixing loops. The boom is spliced between D16-17 & D30-31 and is held together with the mounting screws for these elements. When tightening the nuts on the parasitic elements, be careful not to torque them too tightly. Snug down the nuts, align the elements, and use a screwdriver for the final tightening. A 1/4" nut driver is almost mandatory for this job! Install 3/4" BM brackets at D13, D21 & 33 as shown in the illustrations using 2" machine screws. Attach the driven element with the 5/16-18 nut provided. If only one antenna is being built, it doesn't matter which way the loop is oriented. If multiple antennas are to be stacked, see "Instructions for Stacking Loop Yagis." a separate instruction sheet packed with multiple antennas.
- 2) Install the cable assembly through the hole in the driven element mounting bolt, observing proper orientation as shown on page 2, and solder the ends to the ends of the loop. Solder the inner conductor first. Bend the connector forward and secure it to the boom with the connector bracket provided. (The bracket is secured by the nut for D1.)
- 3.) At this time assemble the two piece 3/4" sub boom using the supplied hardware and angle brackets, and tighten for a good snug fit. Attach the two 3" x 4" sub boom plates (small ones, with no u-bolt holes) to the sub boom ends, and the short BM brackets on the main boom at D13 & 33, using the 8-32 X 1 1/4" screws provided. Do not make them tight yet. Position the 3.5" x 4" boom to mast plate with u-bolt holes, at D21 and the large BM Bracket. This is the balance point of the antenna. Attach the two 2" stainless U-bolts now.
- 4.) Support the 3347LY on it's support mast, with the 2" u-bolts and adjust the main boom until the boom sag is minimized. Tighten the hardware to lock the sub boom plates in place. There should be hardly any sag in the boom when this is accomplished. Attach the feedline and tape it to the bottom of the boom. Seal all coax connections with butyl rubber, silicone RTV or equivalent. Coat the back of the female N connector on the antenna as well.
- 5) The SWR should be 1.3:1 or better. Additional tweaking can be accomplished by adjusting the distance between the driven element and R1 or by adjusting the shape of the driven element.



177 DIXON RD.
 LEBANON, ME. 04027
 TEL: 207-658-7758 FAX: 207-658-4337
 www.directive-systems.com

DIMENSIONS OF 903 MHz LOOP YAGI, MODEL 3347LY(K)

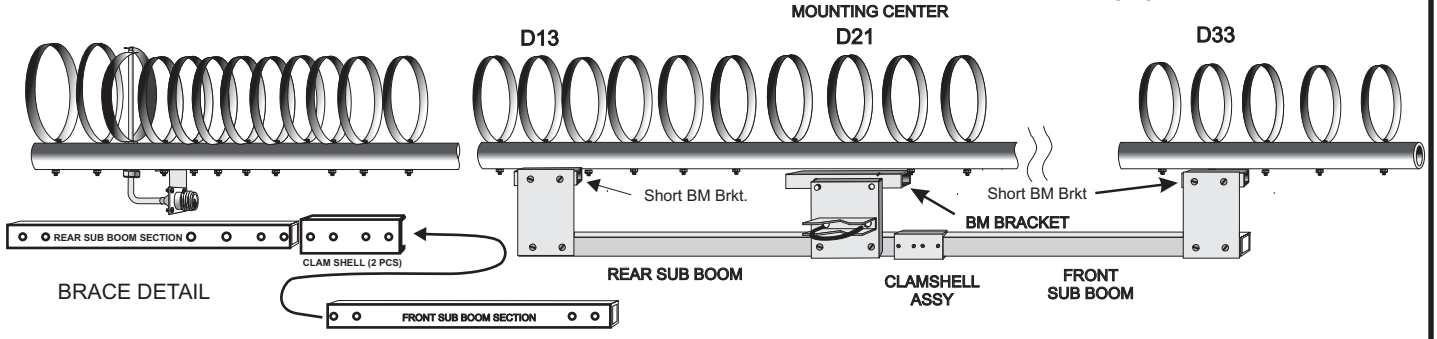

Element	Spacing from end of boom	Circumference	Element	Spacing from end of boom	Circumference	Element	Spacing from end of boom	Circumference
R2	0.50	13.931	D14	60.270	11.526	D30	142.110	11.026
R1	4.945	13.931	D15	65.385	11.526	D31	147.225	11.026
DE	6.319	13.486	D16	70.500	11.526	D32	152.340	11.026
D1	7.928	11.893	D17	75.615	11.526	D33	157.455	11.026
D2	9.121	11.893	D18	80.730	11.526	D34	162.570	11.026
D3	11.678	11.893	D19	85.845	11.171	D35	167.685	11.026
D4	14.236	11.893	D20	90.960	11.171	D36	172.800	11.026
D5	16.032	11.893	D21	96.075	11.171	D37	177.915	10.883
D6	19.351	11.893	D22	101.190	11.171	D38	183.030	10.883
D7	24.466	11.893	D23	106.305	11.171	D39	188.145	10.883
D8	29.580	11.893	D24	111.420	11.171	D40	193.260	10.883
D9	34.695	11.893	D25	116.535	11.026	D41	198.375	10.883
D10	39.810	11.893	D26	121.650	11.026	D42	203.490	10.883
D11	44.925	11.893	D27	126.765	11.026	D43	208.605	10.883
D12	50.040	11.526	D28	131.880	11.026	D44	213.720	10.883
D13	55.155	11.526	D29	136.995	11.026			

Note: All dimensions are in inches

The boom diameter is 1 inch, and it is drilled for 4-40 hardware (no. 33 drill bit). The driven element hole is 5/16 inch dia. All elements are 0.032 inch thick and 0.375 inch wide. Note that the element spacing from D7 on is 5.115 inches. The driven element is installed in the 5/16" hole in the boom. The feed coaxial cable (0.141 inch semi rigid) goes through the mounting bolt and is formed in a 90 degree bend so that the connector bracket can be bolted to the boom at Director #1 using the D1 hardware. Bend coax around your thumb for support. (It may "kink" otherwise.) The connector end is soldered to the open ends of the brass element. Allow a 1/4" gap at the feedpoint. For best match, the driven element should be approximately 4 inches high; this makes it wider than it is tall. This shape can be adjusted for best match. This antenna is based on work done by G3JVL.

