

SOME NOTES ON A 50 MHZ CONTEST ARRAY

By David C. Olean K1WHS
RFD #1 Box 282
West Lebanon, Maine
04027

Contesting from the state of Maine poses many problems not encountered in the more populous areas of the country. If you put a big yagi up 100 ft or so in the air, and try your hand at contesting, you will not be able to compete with stations in more populated areas. The sheer number of QSOs possible there, and a lack of grids available in your immediate area, again due to lack of population, will put you way down in the pack. There is really not much to do that can eliminate these geographical problems, but I had an idea to upgrade the antenna to try to close the gap.

The plan was to evolve a new antenna system as time permitted, and evaluate the results along the way. Cost constraints coupled with time availability problems have stretched this project out over several years.

Big 50 mhz antenna systems are not new. In fact, a renaissance is in progress now with 50 mhz EME becoming quite popular. W4HHK and W1BU had large colinear systems back in the 50s. Recently, I have been aware of a few New England stations running large 50 mhz systems. W1FC ran a large 2 stack array on Fack Monadnock, NH, as does W2SZ/1 on Mt Greylock. W1VD ran a 6 yagi stack from Connecticut and was very successful. The plan was to start with a dual stack system similar to what I had observed at W1FC in the early 80s. Figure 1 documents the basic W1FC setup. My idea was to observe the benefits of switching between two yagis in a vertical stack and to compare a single yagi with both arrayed together. This system was built at West Lebanon in 1986 and was used sparingly over the course of the summer. The relay system was left hanging out in the weather and was disconnected as bad weather approached.

During the summer, the ability to switch between two antennas at different heights proved to be a minor advantage as small improvements could be had by optimizing the antenna height and hence the elevation angle of the array. Combining both antennas usually would outdo either individual antenna. A big advantage of the system lay in the ability to rotate two antennas to two different beam headings. Quick exchanges to different geographical areas is a big deal for a contest station. The signal improvement available with different arrival angles convinced me that some form of electrical beam steering off the horizon would be worthwhile.

Some goals for the new system were developed. These included:

- a. A large aperture array to develop serious gain.
- b. A broad horizontal beamwidth
- c. Ability to switch antennas at different heights to give versatility in takeoff angle.
- d. Ability to steer the array in elevation to pick the optimum angle of arrival.

The capability to instantly change your elevation angle seemed to be a big plus with a large antenna array, but there are tradeoffs. The antennas chosen for all these tests were a set of Chen and Cheng yagis for 50 mhz. These antennas packs lots of gain with very low wind loading, an advantage when four yagis are combined. The steering effects are possible with any yagi. For different propagation forms, the array should adapt to provide an optimum match to that particular propagation. For instance, Tropo is

strictly an on the horizon game. I expected all signals to be best on the highest antenna. Es or sporadic E should provide a widely varying arrival angle depending on the opening in progress. Big benefits should be had here. F2 should allow for similar tricks as Es. The angles are never the same. Aurora should provide some chance to tilt the array. An uptilt may provide an opportunity to work more southerly stations than would be available if the antenna was stuck on the horizon. The big improvement I wanted to see was in ionospheric forward scatter. A narrow main lobe can be bad for paths that are not optimum. Specifically, close in scatter at 400 to 500 miles is more easily worked with a low yagi with lots of high angle radiation. Scatter at distances over 900 miles requires a very low angle of radiation. A steerable four yagi array would optimize both paths, I thought.

The hardware started to go together in late spring, 1988. I had a 90 ft tower located on the ridge out behind my house., Elevation is about 860 ft asl on very rocky terrain. In fact, the whole ridge is a solid rock ledge. Figure 2 shows the four yagi array located on the tower. Each six element 34 ft boom beast is located 24 ft below its companion above. The heights are 90 ,66, 42, and 18 ft. If you analyze the optimum path length for each antenna height, you will find that for sporadic E propagation, the best distances are 1025,925,750, and 400 miles respectively. This height differential really covers alot of geographical area! More on this later! After mounting all the antennas, I installed a remote relay switching box to control the different positions to be selected fom the shack. A run of 7/8 inch hardline ran up to this switching box. RG-8 cable ran from the switch box to each antenna. The diagram of the switching circuit is shown in figures 4 and 5. Figure 4 shows the coax cabling required. Note that K-1 must be a multi position coax relay. There are many available, but I used the Transco "octopus" type. The other relays are SPDT types with the exception of K-5 which is a transfer version.

A few comments on Figure 4 are in order. The switch positions are configured as follows:

1. Upper antenna alone (90 ft high)
2. Both top antennas (90 and 66 ft)
3. Second antenna from top alone (66 ft)
4. All four antennas in phase on horizon
5. All four antennas with beam steering (10 degree uptilt)

The impedance matching is maintained in the system by a series of 2 port power dividers. I used 1/4 wave sections of RG-11 coax. All relays are located in a box at the 78 ft level. One divider is in the box, as are all the relays. It is important to keep track of exact lengths of coax employed from the center of the upper divider thru K-4 and K-5 to the connector on the outside of the box. This dimension must be added to the length of coax extending from K-5 to the middle 2 way divider. It in turn must be made equal to the coax run from the mid 2 way divider down to the bottom 2 way divider. Failure to keep track of jumper lengths could cause some unwanted beam tilt. Extra cable length on the top pair will cause an uptilt. Longer lengths on the bottom pair will cause a downtilt in radiation angle. Try to keep lengths accurate to 1-2 inches. It goes without saying that all cable lengths from each antenna feedpoint to the appropriate 2 way divider port should be equal. Note that K-2 and K-3 are in series with the top two antennas and add some length to the top pair that is not seen in the bottom pair. Adjust accordingly.

I have not given any cable lengths since I would not expect anyone to

build this exact same system. The lengths are dependent upon the yagi type employed along with the stacking distance chosen. If you use Chen and Cheng, we can talk! If you use other designs, the information here should get you started.

I would like to report on some observations made while using this antenna system during the summer of 1988. First off, the bottom two antennas are not yet rotatable unless you climb up there and physically turn them by hand. They will turn from south to west. The top antenna is fully rotatable. The antenna at 66 ft is rotatable from 150 degrees to the west and northeast to about 45 degrees. From Maine, that movement will cover the whole country. On an enhanced tropo scatter type communications, it was very interesting to note that the top antenna very rarely outperformed the one at 66 ft. This was contradictory to what I expected. The lower antenna beat out the top one 90% of the time. Distances from 50 to 300 miles seemed to not alter anything. Lower was better. On certain days the top antenna would be better, but in all cases, when top and second antenna were combined, the signals always came up. At no time did I ever see a situation where either single yagi outperformed the dual stack. Some times, a single yagi approached the dual performance. At other times, the dual stack was vastly superior. It was very easy to see the near 3 dB improvement of yagi stacking gain at these heights. When all four antennas were employed on the horizon, an improvement over the dual stack was noted, but not as much as observed when going from one to two yagis. Two reasons are: The bottom antennas are much lower so are at a disadvantage in raw collecting power. There is also some extra coax in the four stack system, so coax losses are greater in the four stack. I measured about a 1.5 dB improvement in signal strength on local troposcatter signals with the four stack over the two stack. This was 1 dB less than was observed in the top stack. Some might wonder why anyone would expend such effort to obtain 1.5 dB. Of course, a big drop in signal strength was observed everytime I switched in the uptilt. 6 to 8 dB of loss was always obtained when compared to the four on the horizon. It is very interesting to me that all line noise dropped drastically as the beam was uptilted. In fact, the line noise dropped faster than the troposcatter signals. Signal to noise ratio was improved on occasion by uptilting.

The same comparisons were made on sporadic E signals in June and July. The top antenna would still lag behind the lower one at 66 ft, but the degree was not as pronounced. During some openings, the top yagi was louder. Again, the dual stack was always better than any one yagi by about the same amount as observed on local signals.(2.5dB). An interesting phenomenon was observed with the full four stack on Es signals. There was a bigger improvement many times than the 1.5 dB observed on tropo scatter signals. In addition, the deep fading observed on Es signals on one or even two yagis was almost entirely gone. Switching back and forth between one yagi, then all four would produce widely varying results such as a peak in signal on a single yagi being 4 dB below the four stack in one instant, and then several seconds later, the four stack is 20 dB louder than the same single yagi. Prolonged listening on the four stack array confirmed that a large advantage was gained through a reduction in QSB and that the amount was more than one would expect from simple antenna stacking. In short, the four yagis performed much better on Es than they appeared to work on tropo scatter. Switching to uptilt during an Es opening could cause the signal to go up or down depending on conditions at that time. Each opening was different. As an example, several times there

were double hop openings to California that were producing louder signals on the horizon than on the uptilt position. On at least one occasion, the uptilt position improved California and Arizona signals. Several times, there was double hop propagation to Western South Dakota and Wyoming. On each occasion, K1LL in Rapid City was contacted and would peak up almost 10 dB louder with the 10 degree uptilt, while single hop stations in Iowa and Missouri for example, would peak up by the same amount on the four stack with no uptilt. All this at the same time in a three way roundtable! K1LL is almost 1600 miles away, while the other stations were 1100 miles or so. The greater amount of gain in both four stack positions was evident on double hop propagation, while most single hop signals are so loud, that any position chosen works well. Bill Olsen, W3HQT, ran the array for awhile in the June 1988 VHF QSO party and kept remarking that signals were so loud on single hop that he left the switch in the top yagi position out of convenience. A look at log book entries for double hop openings produced some interesting facts. The stations worked included many that ran 10 watts into small yagis or no yagis at all. Plenty of QSL cards indicated QRP radios and AR-6 ringos or wire dipoles. From past experience, I could safely say that such stations were not normally worked with such good signal reports. The large aperture is very evident on the longer haul paths.

The lack of fading on sporadic E paths evident on the four yagi stack can most likely be explained in terms of space diversity. In an antenna system that fills a vertical area some 90 feet high, it is not hard to imagine that as the signal fades out on the 90 ft antenna, it is building up on the antenna at 18 ft or 42 ft. When the four signals are combined in phase, the signal remains at a high level. Many references to space diversity relate that spacings on the order of 25 wavelengths between antennas are required for meaningful improvements in system reliability. With this array, we are talking about only 4 wavelengths in separation, but the obvious effect is very pronounced. Constant switching from the four yagi position would always result in a weaker signal derived from any other combination. The results were sometimes spectacular with 10 to 15 dB drops in signal strength when a single yagi was chosen. Other times produced much less change when a certain height was selected and the signal level was peaking at that height. Other stations contacted would often comment about the steady nature of signals heard from the four stack. The wide variation in optimum range (in miles) for each antenna height as mentioned earlier, comes into play here. With deep fades at different areas of the stacked array, it is possible for signals from widely differing path lengths to be audible over a period of time more so than from a single yagi at a certain height.

Ionospheric scatter propagation is a very difficult mode that requires big antennas and lots of rf power. I was very interested in observing results of stations heard with some degree of uptilt. Normally there is a dead spot in grids worked at 350 to 500 miles on 50 mhz. It is too far for troposcatter type propagation and too close for ionospheric scatter. The typical 50 mhz station runs one yagi up 55 to 75 feet and has a fairly low angle of radiation. The common volume required for a 450 mile path would necessitate an arrival angle of 13.5 degrees on both ends of the circuit. A 550 mile path would require 10 degree tilts on each end. The contest array has a 10 degree uptilt and true to the prediction, the scatter signals really sound enhanced when the tilt angle is optimized for the path in question. Position 5, the four uptilted yagis, could have easily been labelled "Virginia and Ohio Scatter" It would always improve signals

at 500 miles when the array was uptilted. At 750 miles, both positions were equal. Paths of over 800 miles were always much better on the four yagis with no tilt. I never saw an exception to this observation. In the September 88 vhf contest, K1TOL operated this antenna system for most of a day, and observed similar conditions. He indicated that the top two yagis definitely improved signals and the four bay array improved things further." With the tilt switch on, the 4-bay brought in quick scatter from Va and Nc stations who were not being heard on the four bay with no uptilt." He indicated that signals would "pop in" on the four bay system where they would not peak on the single yagi or even the top pair. I believe that he was seeing the space diversity effect manifesting itself on scatter as well.

The array finally got a chance to exercise itself in an F2 session in late December, 1988. The band opened to South America and I was able to point all four yagis due south and evaluate the situation. Stations in northern South America peaked loudest on four yagis, and I had no trouble in working all DX heard on the first or second call. One station in Peru however was the subject of an unbelievable pileup. I first heard him at my house where I have a single yagi up 80 ft. I had only 10 watts so didn't try to call. He was peaking 5X8. When I got to the hilltop and turned on the 10 kw generator, and was waiting for the 4CX1000A to warm up, (an eternity!) I was dismayed to hear the Peruvian quickly fade out to about S3. He was working W9 stations with 5X9+ signals. I did not bother to call at this point. About an hour later, I called CQ on cw just below 50.100 and was surprised to hear the Peruvian station answer with a weak but Q5 signal. I had 10 degrees of uptilt switched in. I tried switching every combination of yagi and evaluated the results several times. He was Q5 on four yagis with uptilt. When the four yagis were switched to the horizon, he was detectable, but unreadable. The top two yagis or either of the top antennas by themselves would produce no hint of a signal at anytime.

It was interesting to try the array out on an EME sked with WA4NJP. Ray runs a 4 bay array of big 8 element yagis that are fully rotatable and designed for moonbounce. My array is not built for EME, but I felt that there was enough gain available to allow my 1000 watts output from the 4CX1000A to make the grade. My biggest problem came in trying to figure out that the signal I heard was coming from beyond the ionosphere and not common garden variety ionospheric scatter. My verification came when both signals would peak and QRM each other due to the 2.5 second delay. The moon was at 10 degrees when the QSO was completed, and it was interesting to switch down to the horizon and lose most of the EME signal, but still hear the ionospheric scatter. The effect was difficult to pick out at first, since both signals sounded identical, and had little doppler shift. When the contact was in the log, Ray turned his array toward Maine, and switched to SSB. The signals went to 5-7 on scatter after I turned my array towards him, and we chatted for half an hour on some of the loudest scatter signal levels I ever heard!!

I did get the chance to computer model the entire six meter antenna system after the design was completed and constructed. (Isn't that always the way!) A version of Mininec 3 as developed by the Naval Ocean Systems Center and further modified by Brian Beesley, K6STI, for plotter output, was used to evaluate the system. I have enclosed several patterns that demonstrate the type of pattern shift obtainable with this antenna system. I should also add that such an extensive antenna system modelled over an imperfect ground requires a substantial computer unless you have a lot of time to spare waiting for the final results. Several plots of the array

show both the E and H planes of various configurations. These include: one yagi at 66 ft, 4 yagis with no uptilt, 4 yagis with 1/4 wave delay, and 4 yagis with 1/2 wave delay. All of these patterns were made over an imperfect ground, and some assumptions had to be made that may have altered the results from that obtained in the real world. The general characteristics of all the patterns seem quite valid and are in line with the observed results.

In summary, a few points should be stressed. The use of beam steering with large 50 mhz arrays for contest work creates several advantages. The ability to instantly change the angle of the antenna to match the arrival angle of propagation can net several decibels of improvement at times. It can fill in the dead spot often found at 400 miles or so. The degree of uptilt can be adjusted to knock down local noise from power lines etc, without destroying the desired signal in the process. A vertical stack of yagis can provide significant amounts of space diversity improvement due to the nature of fading on most ionospheric reflected paths. A tall vertical stack can effectively reduce fading normally seen on such paths. One observation made many times, has caused much head scratching. The ability of the 66 foot antenna to consistently outperform the 90 foot antenna on local signals arriving from over the radio horizon indicates that not all those signals are actually on the horizon. A good guess is that arrival angles for local (non reflected) 50 mhz signals can be anywhere from 0 to 5 or 6 degrees above the horizon. Such factors as path distance and height of antenna at the opposite end of a path all must affect the final angle seen. This is surely an area of further study for someone with a little time to devote to the problem. I think that the concept of a common scatter volume for two stations in communication is one that is not familiar to most amateurs.

Finally, the use of multiple yagis with uptilt capability can provide the obvious advantage of a larger aperture and the gain that is a result. There is no getting around the old cliché "You can't work'em if you can't hear'em." The system described definitely helps out in the hearing'em category!

THIS ANTENNA SCHEME WAS USED AT WIFC/1 ON PACK MONADNOCK, NH. IN THE EARLY 80 S THE TOP ANTENNA WAS FULLY ROTATABLE, THE LOWER ONE WAS PARTIALLY ROTATABLE

ANTENNA #1

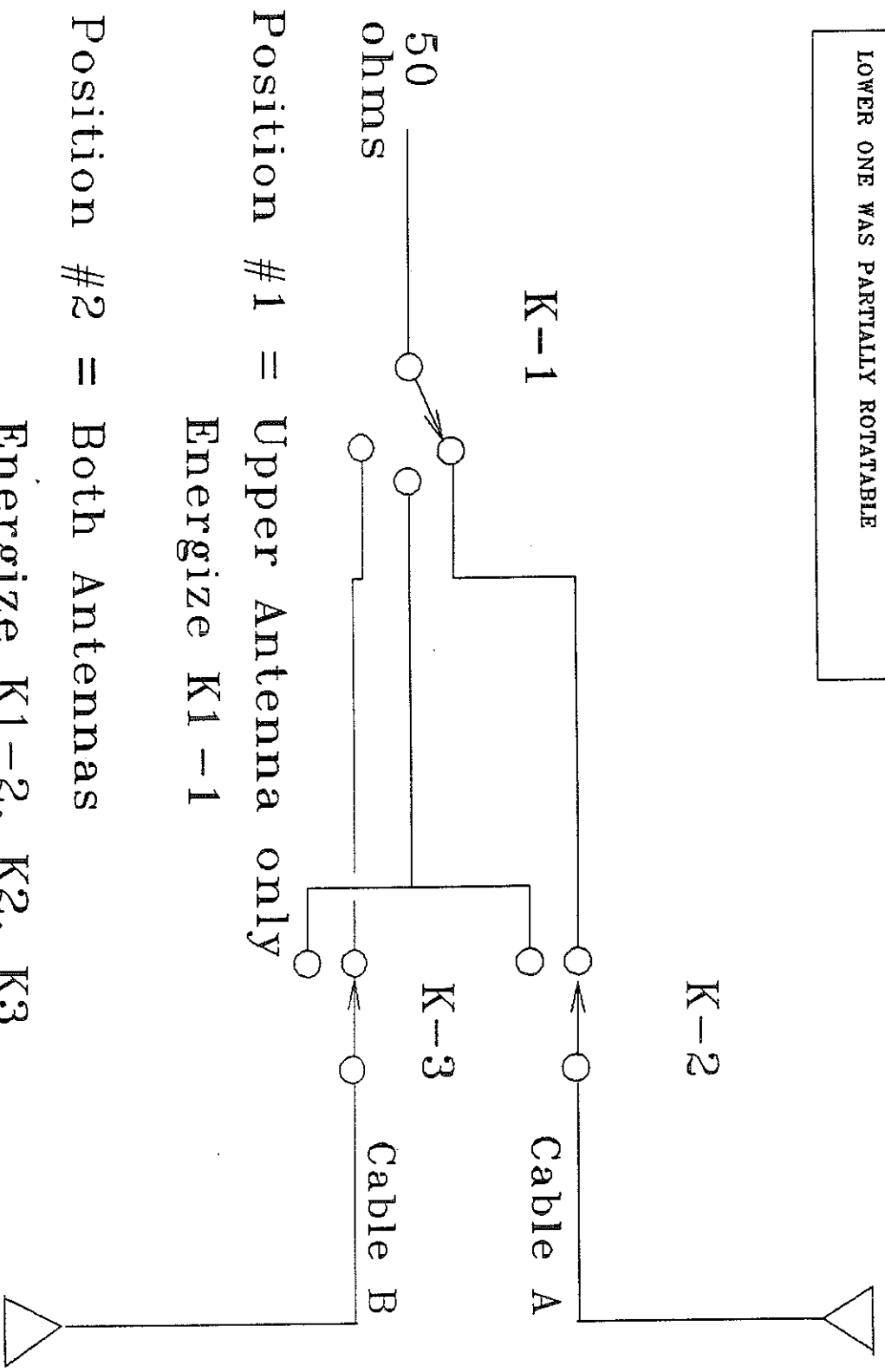

Position #1 = Upper Antenna only
Energize K1-1

Position #2 = Both Antennas
Energize K1-2, K2, K3

Position #3 = Lower Antenna only
Energize K1-3

ANTENNA #2

FIGURE #1

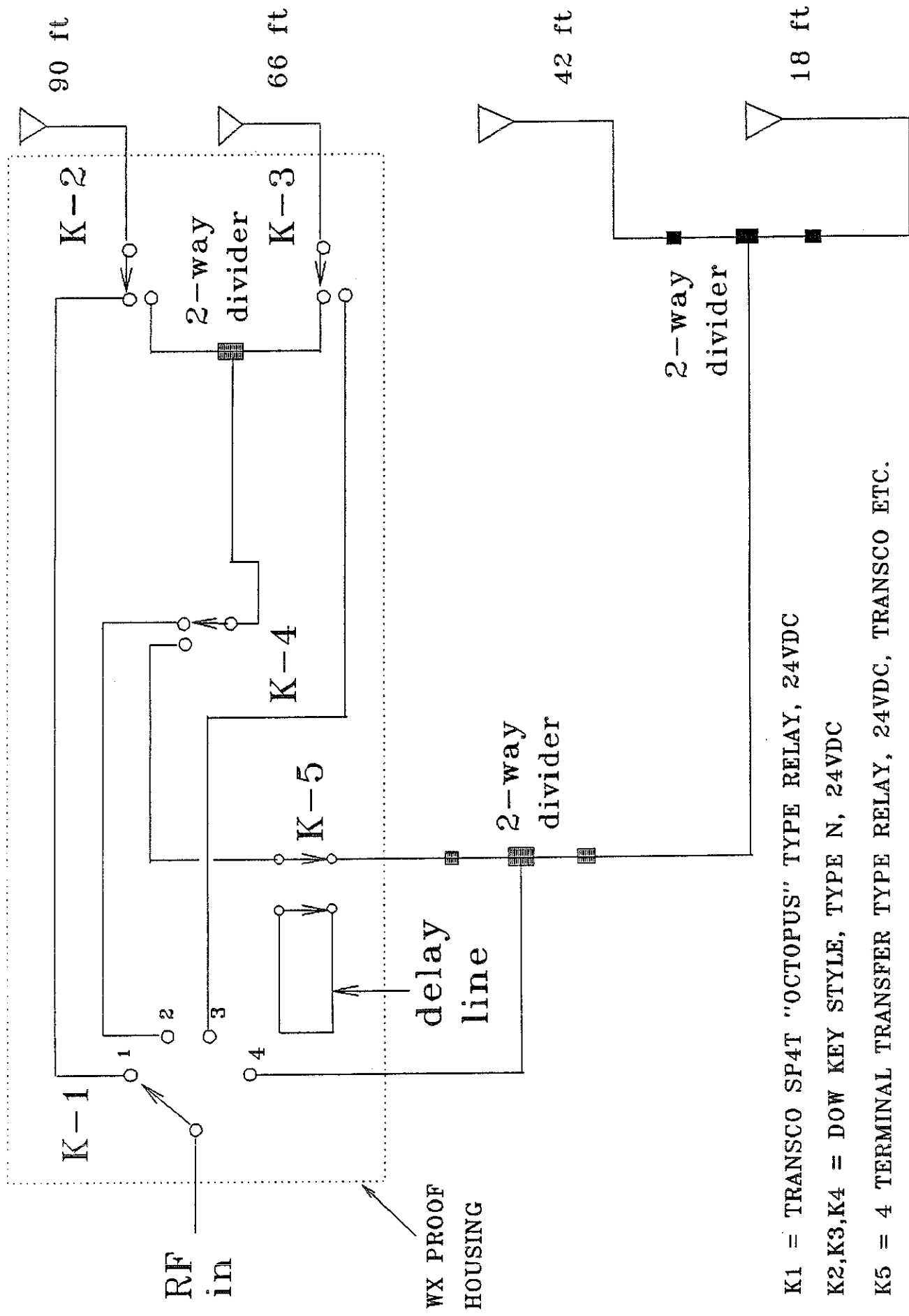

K1 = TRANSKO SP4T "OCTOPUS" TYPE RELAY, 24VDC
 K2,K3,K4 = DOW KEY STYLE, TYPE N, 24VDC
 K5 = 4 TERMINAL TRANSFER TYPE RELAY, 24VDC, TRANSKO ETC.

FIGURE 4

TOWER MOUNTED WX PROOF BOX

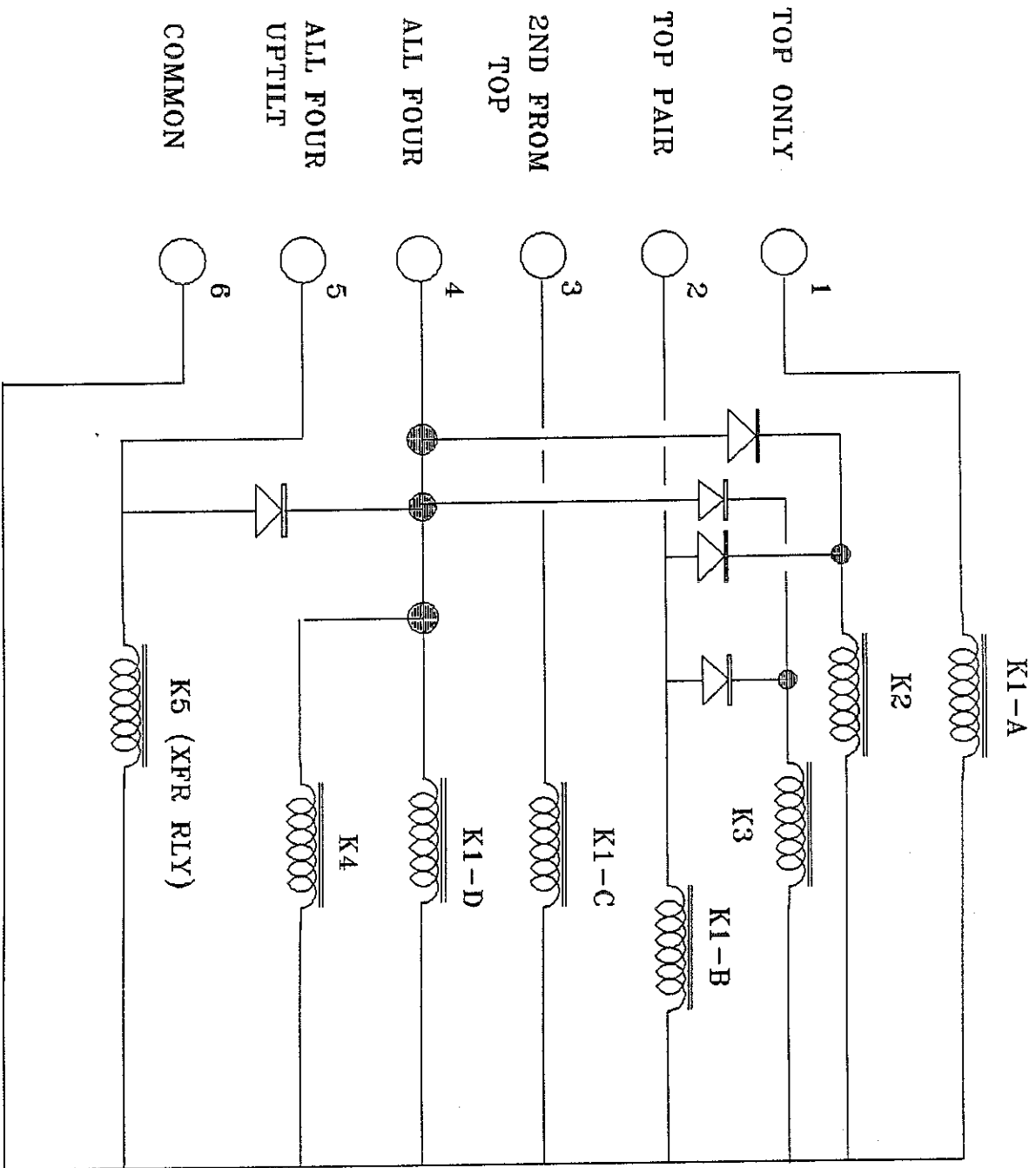

+24 VDC TO PINS 1 THRU 5
 GROUND RETURN TO PIN 6
 OBSERVE POLARITY FOR PROPER
 STEERING DIODE ACTION!

FIGURE 5

5-9-89
 D.C. OLEAN

617-6B four yagi 50 mhz yagi
array with 1/2 wave delay

ground

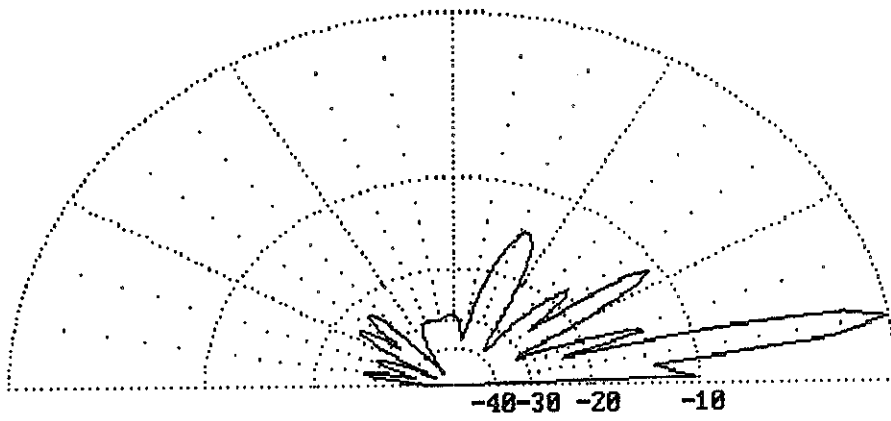

0 dB = 18.84 dBd

50.125 MHz

617-6B four yagi 50 mhz yagi
array

ground

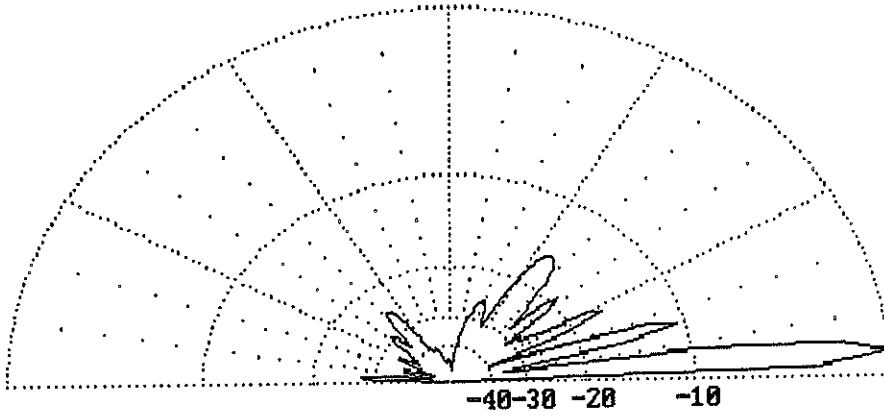

0 dB = 19.57 dBd

50.125 MHz

