



# DIRECTIVE SYSTEMS

177 DIXON RD.  
LEBANON, ME. 04027  
TEL: 207-658-7758 FAX: 207-658-4337  
www.directivesystems.com

## 3456 MHz Loop Yagi Kit, Model 9112LYK

|                     |                   |                       |                      |
|---------------------|-------------------|-----------------------|----------------------|
| Frequency range:    | 3.40 to 3.50 GHz  | Gain:                 | ≈ 25.2 dBI           |
| Number of elements: | 112               | 3 dB Beamwidth        |                      |
| Boom length:        | 144 inches        | (E plane):            | ≈ 8.7°               |
| Boom diameter:      | Dual 0.5" & 0.75" | (H plane):            | ≈ 9.0°               |
| Mast diameter:      | 1 1/2 in. max     | F/B ratio:            | ≥ 25 dB              |
| Weight:             | 4.62 pounds       | Maximum Power:        | 300 W average        |
| Connector:          | Type-N female     | Stacking distance, H: | 21 inches vertical   |
| Wind area:          | 1.0 sq. Ft.       | E:                    | 22 inches horizontal |

### PARTS LIST

| Quantity | Description            | Quantity | Description                   |
|----------|------------------------|----------|-------------------------------|
| 2 pcs    | 0.5" drilled boom      | 18       | Directors 74-91               |
| 1        | .75" square sub-boom   | 18       | Directors 92-109              |
| 2        | reflectors 1&2         | 1 pkg    | 3-48 stainless steel screws   |
| 1        | driven element (Brass) |          | nuts, lockwashers, 8-32 misc. |
| 11       | directors 1-11         |          | hardware                      |
| 7        | directors 12-18        | 2        | 3 x 4" sub boom bracket       |
| 6        | directors 19-24        | 1        | 3 1/2 x 4" boom to mast plate |
| 12       | directors 25-36        | 2        | 1/2" x 2.4" angle bracket     |
| 6        | directors 37-42        | 1        | U-bolt with nuts & saddle     |
| 7        | directors 43-49        | 1        | cable assembly with connector |
| 12       | directors 50-61        |          |                               |
| 12       | directors 62-73        |          |                               |

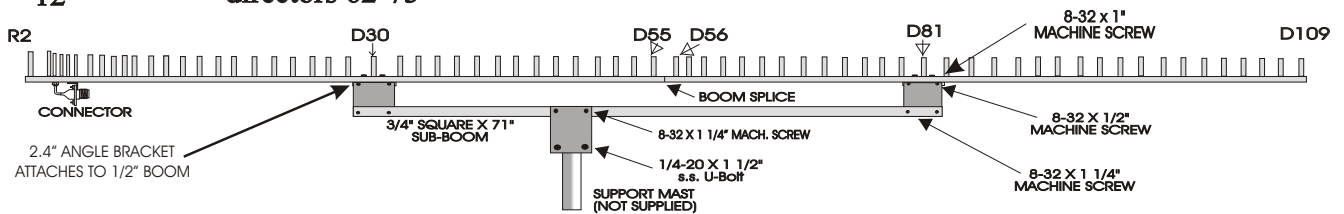

### ASSEMBLY INSTRUCTIONS

- 1) Attach loops to the boom with 3-48 x 3/4" screws, lock washers and nuts in proper sequence. Loops go on the side of the boom marked "TOP" or "X". When tightening the nuts on the parasitic elements, be careful not to torque them too tightly. Snug down the nuts, align the elements and use a screwdriver for the final tightening. A 3/16" nut driver is mandatory for this job! Attach the driven element with the 1/4-20 stainless steel nut. See page 2 for additional assembly hints. If only a single antenna is being built, it does not matter which way the loop is oriented. If antennas are to be stacked, see "Instructions for Stacking Loop Yagis." Put the 2 completed boom pieces together. Use the alignment marks on the booms. The splice is between elements D55 & D56 and is secured by the loop mounting screws of D56, 57 & 58.
- 2) Install the connector-cable assembly through the hole in the driven element mounting bolt and solder the coax ends to the ends of the loop. Allow .25" spacing between brass loop ends. Solder the inner conductor first. Bend the connector bracket forward and secure it to the boom. (The bracket is secured by the nut for D-3)
- 3) Attach the 2.4" angle brackets and sub boom plates (2) with 8-32 hardware. Use 1" screws to attach the angle brackets to the 1/2" boom, and 1/2" screws for the sub-boom plates to the angle brackets. The mounting centers are D-30 & 81. Attach the 3/4" square sub-boom to the two 3 X 4" brackets using 8-32 x 1 1/4" hardware. Align the center mounting holes on the sub boom toward the rear of the antenna so that the holes are at the antenna balance point. Install the 3 1/2 x 4" bracket and U bolt at the balance point of the antenna. Use 8-32 x 1 1/4" hardware. The antenna will appear slightly front heavy with no coax attached to the feed.
- 4) Attach the feedline and tape it to the sub-boom. Seal all connections with silicone RTV or equivalent.
- 5) The SWR should be under 1.5:1 or better. Additional tweaking can be accomplished by adjusting the distance between the driven element and R1 or by adjusting the shape of the driven element.

## LOOP & BOOM DIMENSIONS FOR 9112LY

| Element | Spacing from end of boom | Circumference | Element | Spacing from end of boom | Circumference | Element | Spacing from end of boom | Circumference |
|---------|--------------------------|---------------|---------|--------------------------|---------------|---------|--------------------------|---------------|
| R2      | 1.000                    | 3.852         | D35     | 44.635                   | 2.864         | D72     | 94.030                   | 2.715         |
| R1      | 2.050                    | 3.852         | D36     | 45.970                   | 2.864         | D73     | 95.365                   | 2.715         |
| DE      | 2.518                    | 3.575         | D37     | 47.305                   | 2.821         | D74     | 96.700                   | 2.691         |
| D1      | 2.938                    | 3.086         | D38     | 48.640                   | 2.821         | D75     | 98.035                   | 2.691         |
| D2      | 3.250                    | 3.086         | D39     | 49.975                   | 2.821         | D76     | 99.370                   | 2.691         |
| D3      | 3.917                    | 3.086         | D40     | 51.310                   | 2.821         | D77     | 100.705                  | 2.691         |
| D4      | 4.584                    | 3.086         | D41     | 52.645                   | 2.821         | D78     | 102.040                  | 2.691         |
| D5      | 5.053                    | 3.086         | D42     | 53.980                   | 2.821         | D79     | 103.375                  | 2.691         |
| D6      | 5.920                    | 3.086         | D43     | 55.315                   | 2.781         | D80     | 104.710                  | 2.691         |
| D7      | 7.255                    | 3.086         | D44     | 56.650                   | 2.781         | D81     | 106.045                  | 2.691         |
| D8      | 8.590                    | 3.086         | D45     | 57.985                   | 2.781         | D82     | 107.380                  | 2.691         |
| D9      | 9.925                    | 3.086         | D46     | 59.320                   | 2.781         | D83     | 108.715                  | 2.691         |
| D10     | 11.260                   | 3.086         | D47     | 60.655                   | 2.781         | D84     | 110.050                  | 2.691         |
| D11     | 12.595                   | 3.086         | D48     | 61.990                   | 2.781         | D85     | 111.385                  | 2.691         |
| D12     | 13.930                   | 2.995         | D49     | 63.325                   | 2.781         | D86     | 112.720                  | 2.691         |
| D13     | 15.265                   | 2.995         | D50     | 64.660                   | 2.749         | D87     | 114.055                  | 2.691         |
| D14     | 16.600                   | 2.995         | D51     | 65.995                   | 2.749         | D88     | 115.390                  | 2.691         |
| D15     | 17.935                   | 2.995         | D52     | 67.330                   | 2.749         | D89     | 116.725                  | 2.691         |
| D16     | 19.270                   | 2.995         | D53     | 68.665                   | 2.749         | D90     | 118.060                  | 2.691         |
| D17     | 20.605                   | 2.995         | D54     | 70.000                   | 2.749         | D91     | 119.395                  | 2.691         |
| D18     | 21.940                   | 2.995         | D55     | 71.335                   | 2.749         | D92     | 120.730                  | 2.661         |
| D19     | 23.275                   | 2.900         | D56     | 72.670                   | 2.749         | D93     | 122.065                  | 2.661         |
| D20     | 24.610                   | 2.900         | D57     | 74.005                   | 2.749         | D94     | 123.400                  | 2.661         |
| D21     | 25.945                   | 2.900         | D58     | 75.340                   | 2.749         | D95     | 124.725                  | 2.661         |
| D22     | 27.280                   | 2.900         | D59     | 76.675                   | 2.749         | D96     | 126.070                  | 2.661         |
| D23     | 28.615                   | 2.900         | D60     | 78.010                   | 2.749         | D97     | 127.405                  | 2.661         |
| D24     | 29.950                   | 2.900         | D61     | 79.345                   | 2.749         | D98     | 128.740                  | 2.661         |
| D25     | 31.285                   | 2.864         | D62     | 80.680                   | 2.715         | D99     | 130.075                  | 2.661         |
| D26     | 32.620                   | 2.864         | D63     | 82.015                   | 2.715         | D100    | 131.410                  | 2.661         |
| D27     | 33.955                   | 2.864         | D64     | 83.350                   | 2.715         | D101    | 132.745                  | 2.661         |
| D28     | 35.290                   | 2.864         | D65     | 84.685                   | 2.715         | D102    | 134.080                  | 2.661         |
| D29     | 36.625                   | 2.864         | D66     | 86.020                   | 2.715         | D103    | 135.415                  | 2.661         |
| D30     | 37.960                   | 2.864         | D67     | 87.355                   | 2.715         | D104    | 136.750                  | 2.661         |
| D31     | 39.295                   | 2.864         | D68     | 88.690                   | 2.715         | D105    | 138.085                  | 2.661         |
| D32     | 40.630                   | 2.864         | D69     | 90.025                   | 2.715         | D106    | 139.420                  | 2.661         |
| D33     | 41.965                   | 2.864         | D70     | 91.360                   | 2.715         | D107    | 140.755                  | 2.661         |
| D34     | 43.300                   | 2.864         | D71     | 92.695                   | 2.715         | D108    | 142.090                  | 2.661         |
|         |                          |               |         |                          |               | D109    | 143.425                  | 2.661         |

**Note: All dimensions are in inches**

### ASSEMBLY TIPS:

The 3456 Mhz loop yagi elements are quite small and require more care in assembly than their lower frequency relatives. If reasonable care is used, the results will be worth the extra effort. To assemble each individual loop, push the 3-48 machine screw just slightly through one end of the formed loop. While grasping the machine screw, move the other loop end hole and push it down onto the 3-48 machine screw. When both holes are aligned, push the screw through with your thumbnail. Be careful not to distort the loop. If you have problems, it is a good idea to grasp the screw body with a strong set of needle nosed pliers (they can fit inside the loop better than big fingers!) Guide the screw through both holes. Align the screw slots parallel with loop plane.

Install the individual sets of loops as a group and tighten as you go along. Check your work, and verify director numbers. It is easier to correct mistakes when they happen, rather than later when the antenna is completed! Tighten the nuts by hand, then finish the job using a flat blade screw driver and a machine screwdriver with a 3/16" socket for the 3-48 nuts. Solder the driven element as shown at right, then, with a large iron, apply solder to lock the .141" coax in the 1/4" brass bolt. This will stabilize the VSWR at this frequency.

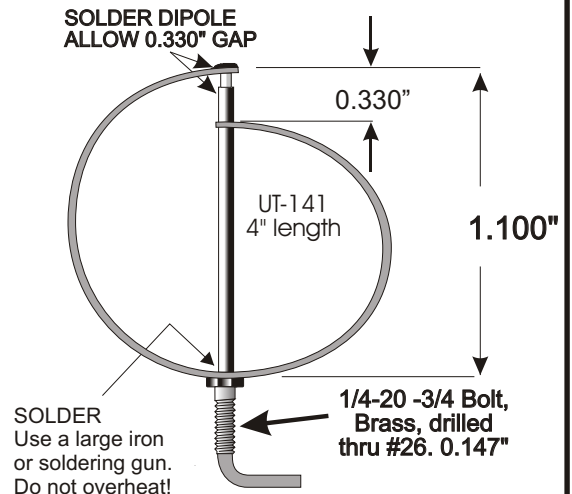

ATTACH CONNECTOR ASSEMBLY  
BRACKET TO D-3 MOUNTING SCREW.