

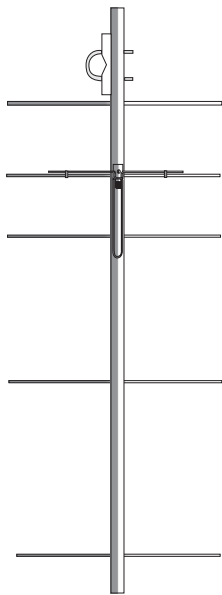

DIRECTIVE SYSTEMS

177 DIXON RD.
 LEBANON, ME. 04027
 TEL: 207-658-7758 FAX: 207-658-4337
 www.directivesystems.com

DS145-5SC 5 ELEMENT 144-148 MHz YAGI ELECTRICAL SPECIFICATIONS



Frequency range: Mhz	144-148
Gain: dBd.....	9.0
Impedance: Ohms.....	50
Connector type	Type N (F) UG-58/U
Front -to- back ratio: dB.....	20
SWR: Typical at resonance.....	≅ 1.2:1
Beamwidth: degrees	
E- Plane	48
H- Plane	56
Sidelobe level: decibels	
E- Plane	-23
H- Plane	-13
Power rating, Continuous: Watts	1500
Stacking Distance: Ft (m)	
E- Plane	8ft 2" (2495)
H- Plane	6 ft1" (1.871)

MECHANICAL SPECIFICATIONS

Boom length: Ft (m.)	72" (1.829)
Turning radius: Ft. (m.)	66" (1.676)
Weight Assembled: Lbs (kg.)	2.8 (1.27)
Max mast size: In. (cm.)	1 1/2 (3.81)
Wind surface area: Ft (m.)	0.5 (.046)
Wind Survival: Mph (km/hr)	100 (160)

PARTS LIST

Boom		BAG # 1 (CONTINUED)	
1 1/4" OD x 0.058 x 36" rear boom 1		Brass T match bars	2
w. coax/ balun assy. attached		U- bolt, s.s. 1/4-20 x 1 1/2"	1
1 1/8" OD x 0.058 x 36" front boom 1		Nut, hex, s.s. 1/4-20	2
Element bundle		Lock washer, split, s.s. 1/4"	2
5 elements w. 2 T-match rods	1	Insulators, element, Delrin®	10
HARDWARE BAG #1		Keepers, s.s. 3/16"	10
8-32 x 1 3/4" machine screw	1	Element assembly tool	1
8-32 s.s. hex nut	1	Assembly instructions	1
#8 split s.s. lock washer	1		

Antenna components should be removed from the shipping carton, and the individual parts should be compared with the parts list on page one of this instruction sheet.

The boom consists of two aluminum tubing sections, both 36" long. The rear boom section already has the balun & driven element connector attached and is the 1 1/4" diameter tube. Assemble the two boom pieces and fasten with the 8-32 x 1 3/4" machine screw and hardware supplied.

The element bundle contains all of the elements needed for assembly. Take time to inventory each one and check off each dimension with Table 1. Some elements vary by one or two millimeters, so extreme care in measuring is required here. Arrange elements in order of descending size and mark each element with a scribe, or sharp tool to properly locate the first keeper position. The scribe dimensions are listed in Table 1 as the "Keeper half length". The keepers are the stainless steel fasteners that slide over the 3/16" dia. Aluminum elements. Note that the reflector element is the longest followed by the brass driven element, and then director #1. Director #9 is the shortest element. Once you have marked each element, and using the hollow assembly tool, push the keeper onto the element until it meets the scribed line. Be careful as the keeper cannot reverse direction if you overshoot the line. You must push the keeper all the way to the end and start over. A good trick is to install the element in a bench vise with the scribed line flush with the edge of the vise jaws. Push the keeper until it is against the edge of the jaws. This way, it is impossible to overshoot the scribed line. Be aware that the keepers are designed to go a certain way. See the figure 6 for proper orientation prior to attaching the keepers. Now attach one keeper to every element as advised in Table 1, and shown below.

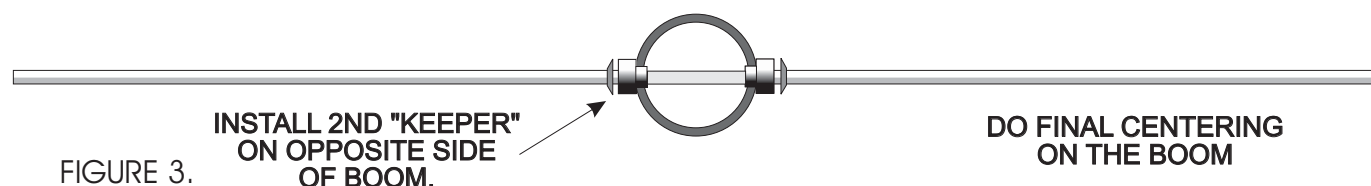
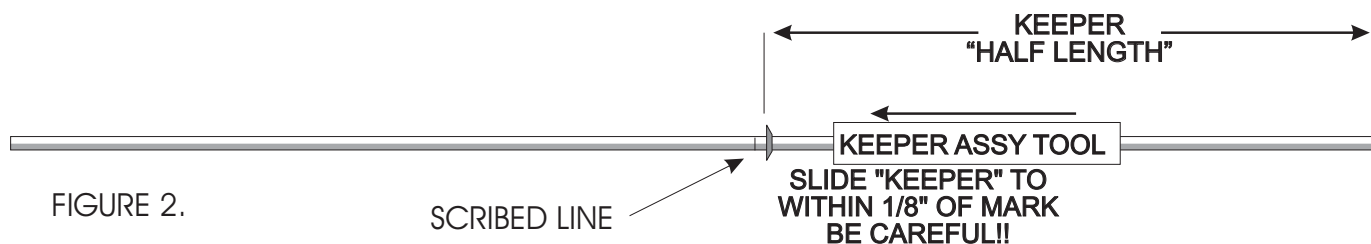

You are now ready to install the elements onto the boom. Start at the rear of the antenna, (the fatter end, with the connector assembly attached) Install a pair of black Delrin insulators in the large 5/16" hole on each side of the boom. They may fit tightly and may have to be tapped into position with a small hammer. Now slide the correct element through the two insulators. Press a second keeper onto the opposite end of the element from the first keeper and push until the element is snugly captured on the insulators. Check that the element is centered on the boom. Equal lengths should extend on either side of the boom. Proceed with each succeeding element until all 11 elements are attached to the boom as shown above. Note that the driven element is brass rod, but is installed as the other elements.

The driven element T-Match assembly is constructed as shown in Figures 4 & 5.

Locate the two lengths of #12 copper wire. Both wires are preformed. One is straight with a flattened end, while the other is bent and flattened on one end. Locate also the brass T-Match bars, and position them on the brass driven element as shown in figure 4.

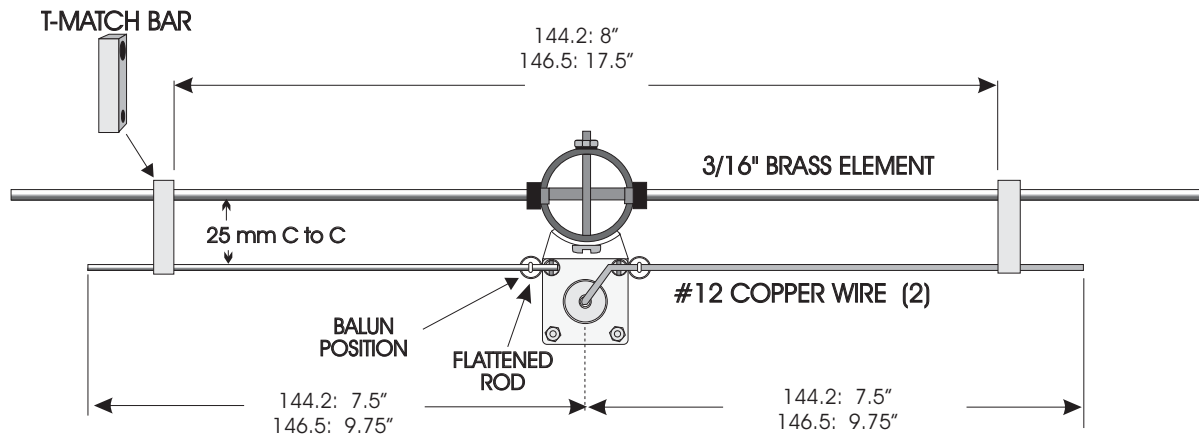
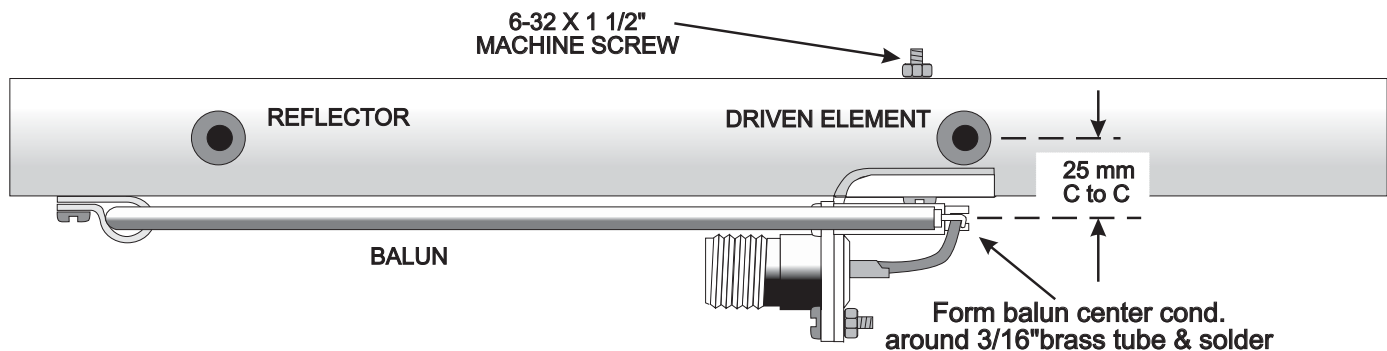

FIGURE 4.

Install the two #12 copper wire T match wires and T match bars on the driven element as shown in the diagram (Figure 4) above. Note that the formed end of the bent T Match wire is inserted into the solder cup of the Type N connector and routed through the pre-assembled blue standoff insulator. Solder the copper wires to the connector center pin and the two blue standoffs. **If you are installing multiple antennas, please be sure that you build each antenna with the same T match wire orientation. In the above drawing, the center pin goes to the right hand side of the antenna as viewed from the back of the connector. Make sure both antennas do the same!** Proper phase relationship is very important here! Align the T match bars parallel with the edge of the connector bracket, and adjust their position as shown in Figure 4 and 5. You can slide the bars carefully into position. Be careful and do not apply excessive force to the blue standoff insulators. They are easily broken with rough handling. You may have to bend the connector bracket slightly to achieve the listed dimensions.

Carefully bend the balun center conductor leads around the T match wires at the blue standoffs, as shown in Figure 5, and solder them both. Adjust the T Match length to the dimensions shown in Figure 4. Note that the T match copper Once the bars and brass tubes are set, you can solder the T Match bars as well. This will complete the assembly of your DS145-5SC. The construction of this antenna will provide many years of consistent performance with no degradation of performance due to corrosion and weathering.



DRIVEN ELEMENT SIDE VIEW

FIGURE 5.

You are now ready to install your antenna. Install the 1 1/2" U-bolt in the rear mounting holes. Note that there are two sets of holes for vertical and horizontal polarization. Once you have the U-bolt installed and the antenna mounted on your support mast and tightened, you can route your feedline along the mast and over to the driven element and connector. Dress the coax against the antenna boom and tighten the connector. Seal the connector body with several layers of good grade vinyl tape. Then apply a layer of butyl rubber antenna sealer or RTV over the tape. This will provide a good vapor barrier and ensure years of trouble free performance. It is also a good idea to spray the driven element and connector assembly with a clear spray such as Rustoleum Clearseal or Krylon clear spray. This will enhance the vapor barrier and prevent oxidation of the brass components.

TABLE 1

ELEMENT DESCRIPTION	ELEMENT LENGTH		KEEPER HALF LENGTH	
	In.	mm.	In.	mm
REFLECTOR	39.88	1013	19.154	486.5
DRIVEN ELEMENT	38.50	978	18.465	469.0
DIRECTOR #1	36.83	935.5	17.630	447.8
DIRECTOR #2	36.63	930.4	17.579	446.5
DIRECTOR #3	36.83	935.5	17.677	449.0

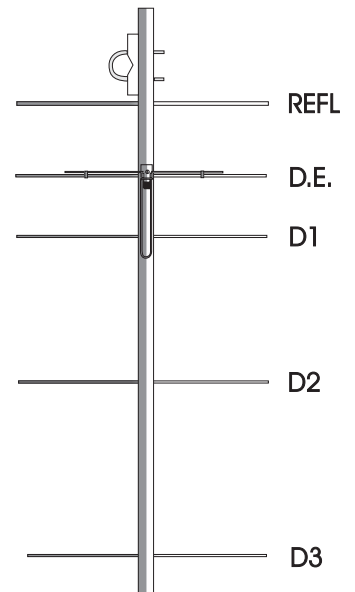

DS145-5SC

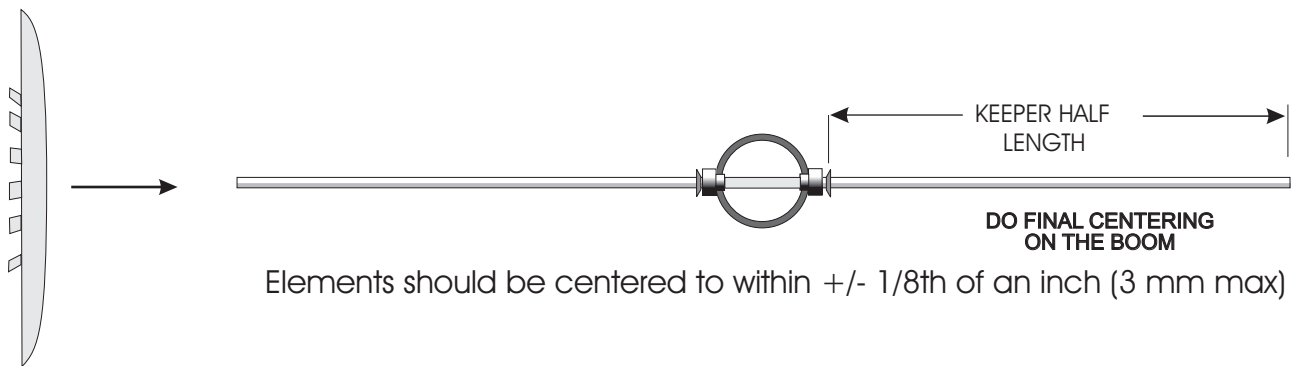

FIGURE 6.
KEEPER DETAIL Note direction of travel!