



DIRECTIVE SYSTEMS

177 DIXON RD.
 LEBANON, ME. 04027
 TEL: 207-658-7758 FAX: 207-658-4337
 www.directive-systems.com

DS50-4HP SIX METER YAGI

| | |
|---------------------------------------|-----------------------------------|
| Frequency range: MHz | 50-51 |
| Gain: dB..... | 8.2 |
| Impedance: Ohms..... | 50 |
| Connector type | Type N (F) UG-58/U (UHF optional) |
| Front -to- back ratio: dB..... | 25 |
| SWR: Typical at resonance..... | 1.2:1 |
| Beamwidth: degrees | |
| E- Plane | 51 |
| H- Plane | 65 |
| Sidelobe level: degrees | |
| E- Plane | -25 |
| H- Plane | -14 |
| Boom length: Ft (m) | 12' 4" (3.759) |
| Turning Radius: In. (m) | 83 (2.11) |
| Wind Area: Sq. Ft. (M) | 1.3 (0.121) |
| Wind Survival: mph (kph) | 110 (175) |
| Weight, assembled: Lbs. (kg) | 10 (4.54) |
| Power rating, Continuous: Watts | 1500 |
| Stacking Distance: Ft (m) | |
| E- Plane | 20'6.8" (6.270) (Maximum) |
| H- Plane | 15 ft 8" (4.775) (Maximum) |

HARDWARE KIT

| DESCRIPTION | QUANTITY |
|--|----------|
| BAG #1 | |
| 1 1/2" U-bolts | 4 |
| Saddles, machined aluminum | 4 |
| 1/4" stainless steel hex nuts | 10 |
| 1/4" split stainless steel lockwashers | 8 |
| 8-32 x 1" stainless steel machine screws | 8 |
| 8-32 stainless steel hex nut | 8 |
| #8 split stainless steel lock washers | 8 |
| BAG #2 | |
| 2" stainless steel U-Bolts | 2 |
| 1 3/8" U-Bolts | 2 |
| 1/4" stainless steel hex nuts | 4 |
| 1/4" split stainless steel lockwashers | 4 |
| 5/16" stainless steel hex nuts | 4 |
| 5/16" split stainless steel lockwashers | 4 |
| BAG #3 | |
| Stainless steel hose clamps | 2 |
| Gamma shorting Bar with screws etc. | 1 |



DIRECTIVE SYSTEMS

177 DIXON RD.
LEBANON, ME. 04027
TEL: 207-658-7758 FAX: 207-658-4337
www.directivesystems.com

DS50-4HP 50 MHz Yagi

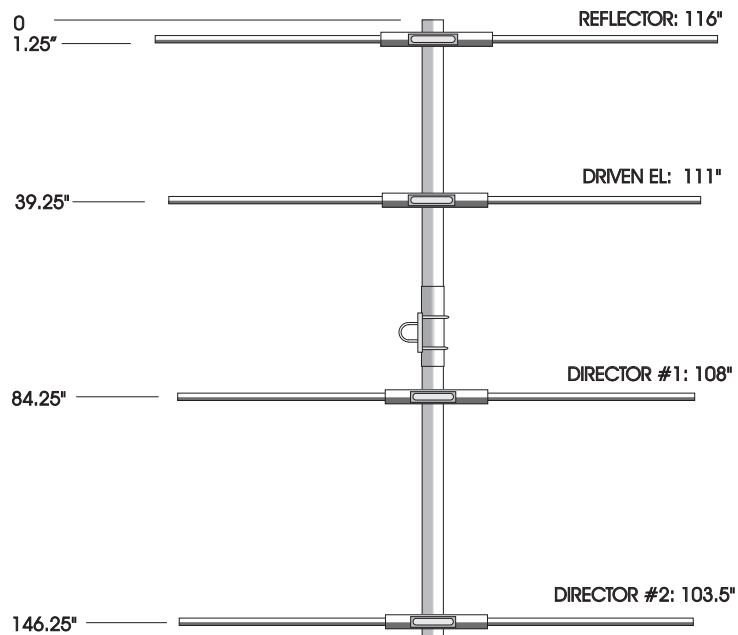
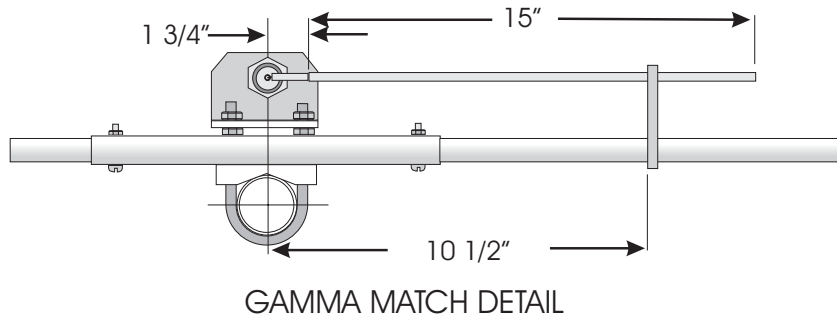
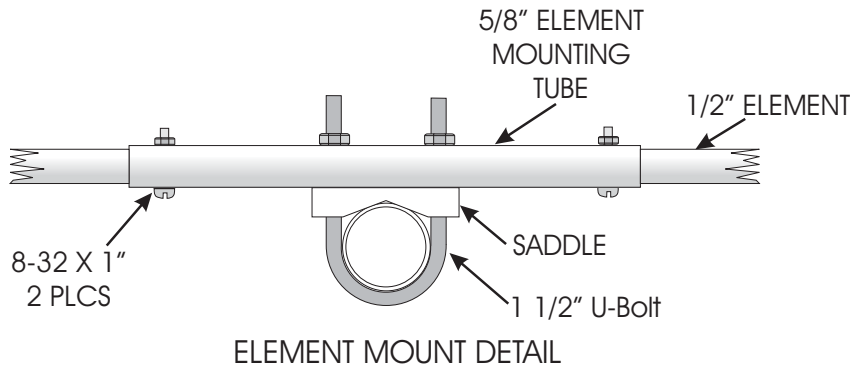



DIRECTIVE SYSTEMS

177 DIXON RD.
LEBANON, ME. 04027
TEL: 207-658-7758 FAX: 207-658-4337
www.directivesystems.com

DS50-4HP INSTRUCTIONS

1. Locate the element pieces. Note that two equal length $1/2$ " pieces make up each element, along with a $7\ 3/4$ " mid-splice section. Slide the $1/2$ " dia. end pieces into each end of the $5/8$ " drilled mid sections. Use the $8-32 \times 1$ " machine screws to secure the elements to the mid sections according to the drawing. Note that each element length is marked on the drawing, and that they decrease in length from rear to front. Check each element for proper length, then tighten all element screws.
2. Assemble the boom sections. The 14" mid section is slotted for the $1\ 1/2$ " s.s.worm clamps. Insert the each of the end sections $3\ 3/8$ " into the mid section and tighten the worm clamps. Then mark the element locations on the boom per the dimensions on page 2.
3. Assemble all elements on the boom with u-bolts and saddles according to the drawing. Use lockwashers under all the u-bolt nuts except the driven element. Note that there is $1\ 1/4$ " from the end of the rear boom to the reflector. The last director will be about $1\ 1/4$ " from the front end of the boom. Align all elements and tighten the u-bolt nuts.
4. Locate the driven element connector assembly and place it on the driven element u-bolt with the connector side facing toward the front of the antenna. Tighten the connector bracket with two $1/4-20$ nuts and split lockwashers. Solder the gamma match arm to the connector and slide the gamma bar over the gamma rod and driven element. Observe the drawing on page 2, and set the gamma-match dimensions as shown.
5. Attach the $1\ 3/8$ " u-bolts and 2" u-bolts to the boom to mast $3" \times 5"$ bracket and locate it at the balance point of the antenna. Connect and tape your main feedline to the connector. Seal it well, and tape coax to the boom. The gamma match settings should produce a response as shown below.

